

*TB 9-6625-2171-35

CHANGE 1

DEPARTMENT OF THE ARMY TECHNICAL BULLETIN

CALIBRATION PROCEDURE FOR RADIO TEST SET TS3951/PRM34, RECEIVER TEST SET AN/ARM-186, AND COLLINS, MODEL 972Q-4

Headquarters, Department of the Army, Washington, DC
7 December 2006

Distribution Statement A: Approved for public release; distribution is unlimited.

TB 9-6625-2171-35, 24 February 2003, is changed as follows:

1. Remove old pages and insert new pages as indicated below. New or changed material is indicated by a vertical bar in the margin of the page.

Remove Pages
9 and 10

Insert Pages
9 and 10

2. File this change sheet in front of the publication for reference purposes.

By Order of the Secretary of the Army:

Official

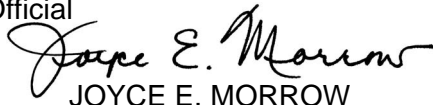

JOYCE E. MORROW

*Administrative Assistant to the
Secretary of the Army*

0628505

PETER J. SCHOOMAKER
*General, United States Army
Chief of Staff*

Distribution:

To be distributed in accordance with IDN 342260, requirements for calibration procedure
TB 9-6625-2171-35.

***TB 9-6625-2171-35**

DEPARTMENT OF THE ARMY TECHNICAL BULLETIN

CALIBRATION PROCEDURE FOR RADIO TEST SET TS3951/PRM34, RECEIVER TEST SET AN/ARM-186, AND COLLINS, MODEL 972Q-4

Headquarters, Department of the Army, Washington, DC
24 February 2003

Approved for public release; distribution is unlimited.

REPORTING OF ERRORS AND RECOMMENDING IMPROVEMENTS

You can improve this manual. If you find any mistakes or if you know of a way to improve these procedures, please let us know. Mail your letter, DA Form 2028 (Recommended Changes to Publications and Blank Forms) directly to Commander, U.S. Army Aviation and Missile Command, ATTN: AMSAM-MMC-MA-NP, Redstone Arsenal, AL 35898-5000. A reply will be furnished to you. You may also provide DA Form 2028 information to AMCOM via e-mail, fax, or the World Wide Web. Our FAX number is: DSN 788-6546 or Commercial 256-842-6546. Our e-mail address is: 2028@redstone.army.mil. Instructions for sending an electronic 2028 may be found at the back of this manual. For the World Wide Web, use: <https://amcom2028.redstone.army.mil>.

		Paragraph	Page
SECTION	I.	IDENTIFICATION AND DESCRIPTION	
		Test instrument identification	1 2
		Forms, records, and reports	2 2
		Calibration description	3 2
	II.	EQUIPMENT REQUIREMENTS	
		Equipment required	4 4
		Accessories required	5 4
	III.	CALIBRATION PROCESS FOR RADIO TEST SET TS3951/PRM34	
		Preliminary instructions	6 5
		Equipment setup	7 5
		RF output level	8 5
		Power measurement	9 6
		Frequency	10 7
		Final procedure	11 8
	IV.	CALIBRATION PROCESS FOR RECEIVER TEST SET AN/ARM-186 AND COLLINS, MODEL 972Q-4	
		Preliminary instructions	12 8

*This bulletin supersedes TB 9-6625-2171-35, dated 11 September 1986, including all changes.

	Paragraph	Page
Equipment setup	13	8
RF frequency accuracy	14	9
RF level output	15	12
VOR modulation	16	12
VOR 9960 FM deviation	17	14
VOR zero	18	15
LOC DDM	19	16
LOC modulation	20	16
Glide slope DDM	21	17
Glide slope modulation	22	18
MKR BCN	23	19
Final procedure	24	19

**SECTION I
IDENTIFICATION AND DESCRIPTION**

1. Test Instrument Identification. This bulletin provides instructions for the calibration of Radio Test Set TS3951/PRM34, Receiver Test Set AN/ARM-186, and Collins Model 972Q-4. TM 11-6625-3015-14 and TM 6625-2976-40 were used as the prime data sources in compiling these instructions. The equipment being calibrated will be referred to as the TI (test instrument) throughout this bulletin.

a. Model Variations. None.

b. Time and Technique. The time required for this calibration is approximately 2 hours for TS3951/PRM34, using the dc and low frequency and microwave technique, and 4 hours for AN/ARM-186 and Collins, Model 972Q-4, using the dc and low frequency technique.

2. Forms, Records, and Reports

a. Forms, records, and reports required for calibration personnel at all levels are prescribed by TB 750-25.

b. Adjustments to be reported are designated (R) at the end of the sentence in which they appear. When adjustments are in tables, the (R) follows the designated adjustment. Report only those adjustments made and designated with (R).

3. Calibration Description. TI parameters and performance specifications which pertain to this calibration are listed in table 1.

Table 1. Calibration Description

Test instrument parameters	Performance specifications			
TS3951/PRM34				
RF output level	-97 dBm from 30 to 80 MHz Accuracy: -4, +3 dBm			
Frequency measurement	Range: 30 to 80 MHz Accuracy: ±2 kHz			
Power measurement	Range: 1 to 50 W (forward power) 1 to 20 W (reverse power) Accuracy: ±20%			
	<u>FOR SERIAL #635 AND UP</u> Accuracy: ±20% (1-2.0 W) +20 to -27% (2.1-9.9 W) ±20% (10-50 W)			
AN/ARM-186 and Collins, Model 972Q-4				
RF frequencies: VOR LOC Glide slope MKR BCN	Frequency: 108.00 and 108.05 MHz Accuracy: ±0.0025% Frequency: 108.10 and 108.15 MHz Accuracy: ±0.0025% Frequency: 334.50 or 334.10 and 334.70 MHz Accuracy: ±0.0025% Frequency: 75.00 MHz Accuracy: ±0.005%			
RF power output: VOR and LOC Glide slope MKR BCN	>-10 dBm >-20 dBm >-20 dBm			
VOR	Frequency	Accuracy	AM	Distortion
	9960 Hz	±0.01%	27 to 33%	<3%
	1020 Hz	±2.5%	5 to 15%	<10%
	30 Hz	±0.01%	27 to 33%	<5%
FM deviation	Frequency: 9960 Hz Accuracy: 480 ±30 Hz peak			
Bearing	Range: 000 to 315° Accuracy: ±1°, except at 000, accuracy is ±0.7°			
LOC	Frequency	Accuracy	AM	Distortion
	90 Hz	±0.01%	18 to 22%	<5%
	150 Hz	±0.01%	18 to 22%	<5%
	1020 Hz	±2.5%	5 to 15%	<10%
DDM	0 DDM; ±0.005 DDM 0.155 DDM; ±0.020 DDM			
RF frequencies: Glide slope	Frequency	Accuracy	AM	Distortion
	90 Hz	±0.01%	36 to 44%	<5%
	150 Hz	±0.01%	36 to 44%	<5%
	DDM	0 DDM; ±0.010 DDM 0.175 DDM; ±0.025 DDM		
MKR BCN	Frequency	Accuracy	AM	Distortion
	400 Hz	±2%	90 to 100%	<15%
	1300 Hz	±2%	90 to 100%	<15%
	3000 Hz	±2%	90 to 100%	<15%

SECTION II EQUIPMENT REQUIREMENTS

4. Equipment Required. Table 2 identifies the specific equipment to be used in this calibration procedure. This equipment is issued with Secondary Transfer Calibration Standards Set AN/GSM-287. Alternate items may be used by the calibrating activity when the equipment listed in table 2 is not available. The items selected must be verified to perform satisfactorily prior to use and must bear evidence of current calibration. The equipment must meet or exceed the minimum use specifications listed in table 2. The accuracies listed in table 2 provide a four-to-one ratio between the standard and TI

5. Accessories Required. The accessories required for this calibration are common usage accessories, issued as indicated in paragraph 4 above, and are not listed in this calibration procedure. The following peculiar accessories are also required for this calibration: Termination, N Jack, dc to 5 GHz, 50 W, Sierra, Model 161A-50 (161A-50) and Low Pass Filter, Telonic, Models TLC125-6EF1 and TLC75-6EF1.

Table 2. Minimum Specifications of Equipment Required

Common name	Minimum use specifications	Manufacturer and model (part number)
AUDIO ANALYZER	Distortion capability: 3 to 15%	Boonton, Model 1120-S/10 (MIS-35954/2)
DIGITAL MULTIMETER	Range: 2 mV to 10 V ac at 30 to 1020 Hz; 5.5 V dc Accuracy: $\pm 1\%$	Hewlett-Packard, Model 3458A/E02 (MIS35947/1)
DUAL VOLT POWER SUPPLY	Range: -8 to +8 V dc Accuracy: $\pm 1\%$	Tektronix, Type PS503A (MIS-30526/6)
FREQUENCY COUNTER	Range: 29 Hz to 334.7 MHz Accuracy: $\pm 0.000625\%$	Fluke, Model PM6681
MEASURING RECEIVER	Range: 5 to 44% modulation Accuracy: 2.5%	Hewlett-Packard, Model 8902A with power sensor Hewlett-Packard, Model 11722A (7917002 or 7911261)
OSCILLOSCOPE	Sweep range: 0.1 ms to 10 μ s Vertical range: 0.5 V/div Accuracy: $\pm 3\%$	Tektronix, Model 2465B (OS288/G)
POWER METER	Range: -10 to -20 dBm Accuracy: $\pm 5\%$ Range: 1 to 10 mW Accuracy: $\pm 3\%$	Hewlett-Packard, Model E12-432A (MIS-30525) w/thermistor mount, Hewlett-Packard, Model 478A-H75
POWER STANDARD ASSEMBLY	Range: 50 MHz at 10 to 40 W	Directional Coupler, Maury, Model 4098A (7916259)
RF POWER AMPLIFIER	Range: 30 to 80 MHz at 3 to 40 W	Antenna Research, Model 757LC (MIS45845)
SIGNAL GENERATOR	Range: 30 to 80 MHz Accuracy: ± 2 kHz	Wiltron, Model 68347M
SPECTRUM ANALYZER	Range: 30 to 80 MHz Sensitivity: -101 dBm	(AN/USM-489A)
ZIFOR	Range: 0 to 360° Accuracy: $\pm 0.02^\circ$	Collins, Model 478A-3 (478A-3)

SECTION III CALIBRATION PROCESS FOR RADIO TEST SET TS3951/PRM34

6. Preliminary instructions

a. The instructions outlined in paragraphs **6** and **7** are preparatory to the calibration process. Personnel should become familiar with the entire bulletin before beginning the calibration.

b. Items of equipment and accessories used in this procedure are referenced within the text by common name as listed in table 2 and 3.

c. Unless otherwise specified, verify the result of each test and, whenever the test requirement is not met, take corrective action before continuing with the calibration. Adjustments required to calibrate the TI are included in this procedure. Additional maintenance information is contained in TM 11-6625-3015-14 for this TI.

d. Unless otherwise specified, all controls and control settings refer to the TI.

7. Equipment Setup

WARNING

HIGH VOLTAGE is used or exposed during the performance of this calibration. DEATH ON CONTACT may result if personnel fail to observe safety precautions. This unit uses a lithium-sulfur dioxide battery. Special handling may be necessary IAW TM 11-6625-3015-14.

a. Remove bottom cover from TI.

b. Disconnect battery from battery connector and connect dual volt power supply output to battery connector while observing polarity.

c. Connect digital multimeter to dual volt power supply output and adjust until digital multimeter indicates +5.5 V dc.

8. RP Output Level

a. Performance Check

(1) Connect spectrum analyzer RF input to TI **RADIO** connector.

(2) Set **MODE** switch to **SENS SQ** and press **PUSH-TO-TEST** button.

(3) For SN 1 through 634, adjust spectrum analyzer to observe frequencies from 30 to 75 MHz. If output levels do not indicate between -94 and -100 dBm from 30 to 75 MHz, perform **b** below. For SN 635 and above, adjust spectrum analyzer to observe frequencies from 30 to 80 MHz. If output levels do not indicate between -95 and -101 dBm from 30 to 80 MHz, perform **b** below.

b. Adjustments. Adjust R41 (fig. 1) for overall output levels and C29 (fig 1) for higher frequency output levels for spectrum analyzer indications between -94 and -100 dBm for SN 1 through 364 and between -95 and -101 dBm for SN 635 and above (R).

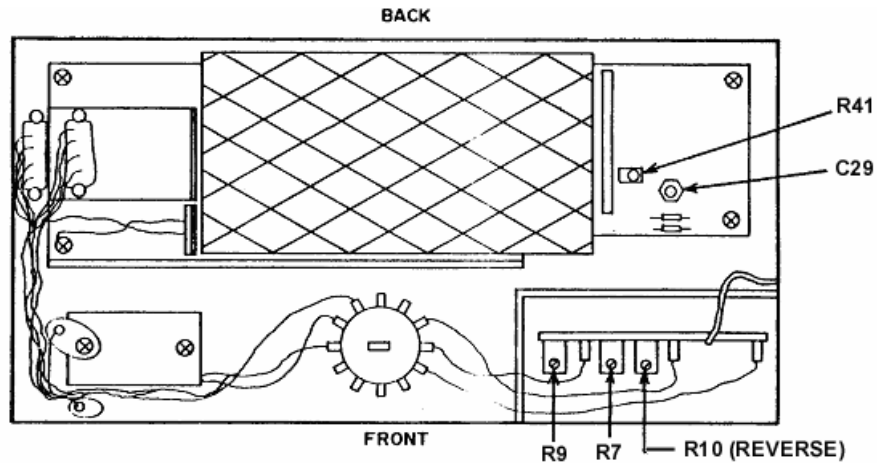

Figure 1. Test instrument - bottom view.

9. Power Measurement

a. Performance Check

- (1) Connect equipment as shown in figure 2.

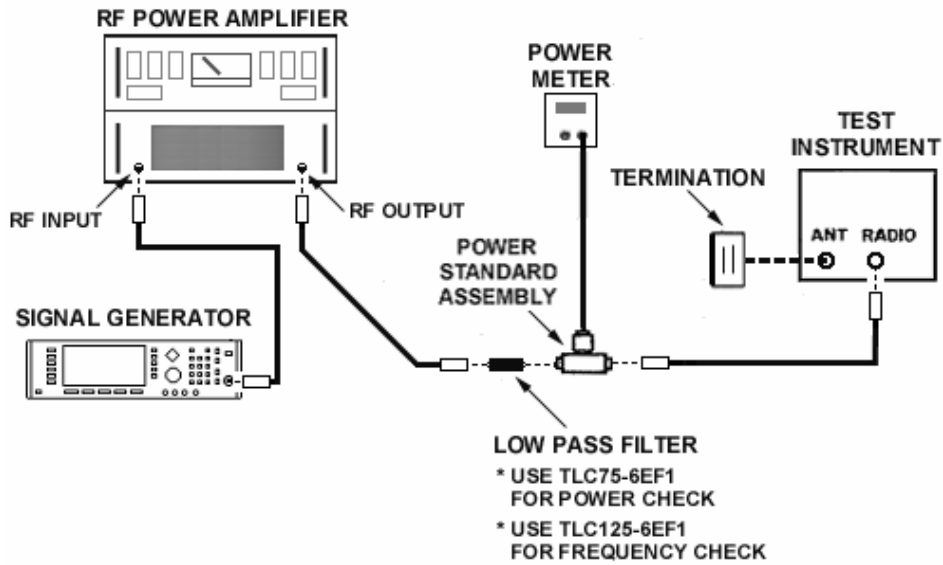

Figure 2. Power and frequency check – equipment setup.

- (2) Set **MODE** switch to **FWD PWR** position.
- (3) Energize all equipment and allow at least 15 minutes for warm-up.
- (4) Compute power meter reading that corresponds to 40 W, using power standard assembly output calibration factor at 50 MHz. (See power standard assembly test report.)
- (5) Adjust signal generator for a frequency of 50 MHz and adjust signal generator output level to within RF power amplifier input operating range.
- (6) Press **PUSH-TO-TEST** pushbutton and adjust RF power amplifier gain control for a 40.0 W indication on TI display. If power meter does not indicate within 20 percent of reading computed in (4) above, perform **b**(1) and (2) below.
- (7) Repeat technique of (4) through (6) above for 1.0 W (3.0 W for TIs with S/N 1 through 634), except perform **b**(1) and (3) below at 1.0 W only.
- (8) Reverse TI **RADIO** and **ANT** connections.
- (9) Set **MODE** switch to **RVS PWR** position and repeat (4) through (7) above at 20.0 and 1.0 W (20.0 and 3.0 W for TIs with S/N 1 through 634), except perform **b**(4) and (5) below.

b. Adjustments

- (1) Adjust RF power amplifier for power meter reading computed in **a**(4) above.
- (2) Adjust R9 (forward) (fig. 1) until TI display indicates 40.0 W (R).
- (3) Adjust R7 (forward) (fig. 1) until TI display indicated 1.0 W. Repeat (1) through (3) above as necessary to obtain best in-tolerance conditions throughout the range of instrument.
- (4) Adjust RF power amplifier for power meter reading computed in **a**(4) above.
- (5) Adjust R10 (REVERSE) (fig. 1) until TI display indicates 20.0 W (R).

10. Frequency

a. Performance Check

- (1) Connect equipment as shown in figure 2.
- (2) Set **MODE** switch to **FREQ** position.
- (3) Adjust signal generator and RF power amplifier levels for approximately 5 W as indicated on RF power amplifier meter and adjust signal generator frequency until TI display reads 30.0 MHz. Signal generator frequency display will indicate between 29.998 and 30.002 MHz.
- (4) Repeat technique of (3) above for TI display and signal generator frequency display indications listed in table 4. Signal generator frequency display will indicate within limits specified.

b. Adjustments. No adjustments can be made.

Table 4. Frequency Accuracy

Test instrument display indications (MHz)	Signal generator frequency display indications (MHz)	
	Min	Max
40.0	39.998	40.002
50.0	49.998	50.002
60.0	59.998	60.002
70.0	69.998	70.002
80.0	79.998	80.002

11. Final Procedure

- a. Deenergize and disconnect all equipment and reinstall protective cover on TI.
- b. Annotate and affix DA label/form in accordance with TB 750-25.

**SECTION IV
CALIBRATION PROCESS FOR
RECEIVER TEST SET AN/ARM-186 AND COLLINS MODEL 972Q-4**

12. Preliminary Instructions

- a. The instructions outlined in paragraphs 12 and 13 are preparatory to the calibration process. Personnel should become familiar with the entire bulletin before beginning the calibration.
- b. Items of equipment and accessories used in this procedure are referenced within the text by common name as listed in table 2 and 3.
- c. Unless otherwise specified, verify the result of each test and, whenever the test requirement is not met, take corrective action before continuing with the calibration. Adjustments required to calibrate the TI are included in this procedure. Additional maintenance information is contained in TM 11-6625-2976-40 for this TI.
- d. Unless otherwise specified, all controls and control settings refer to the TI.

13. Equipment Setup

WARNING

HIGH VOLTAGE is used or exposed during the performance of this calibration. DEATH ON CONTACT may result if personnel fail to observe safety precautions. REDUCE OUTPUT(S) to minimum after each step within the performance check.

- a. Remove TI from case.
- b. Remove both batteries from TI.
- c. Position controls as listed in (1) through (11) below:
 - (1) **BATTERY PWR** switch to **OFF**.
 - (2) **MKR BCN PWR** switch to **OFF**.
 - (3) **GLIDE SLOPE PWR** switch to **OFF**.
 - (4) **GLIDE SLOPE UP-OC-DOWN** switch to **OC**.
 - (5) **LOC PWR** switch to **OFF**.
 - (6) **LOC LEFT-OC-RIGHT** switch to **OC**.
 - (7) **LOC 1020HZ** switch to **OFF**.
 - (8) **VOR PWR** switch to **OFF**.
 - (9) **VOR** bearing switch to **000**.
 - (10) **VOR 1020HZ** switch to **OFF**.
 - (11) **ATTEN** controls to **0**.

CAUTION

Use extreme care when connecting power to TI. Damage will result if connections are made improperly.

- d. Connect dual volt power supply + (positive) terminal to pin A of J2 located in TI BATTERY section, - (negative) terminal to pin B, and common terminal to pin C.
- e. Adjust both dual volt power supply outputs to 8.0 V.
- f. Set **BATTERY PWR** switch to **ON** and allow 15 minutes for warm-up.

NOTE

Only one TI section should be energized at a time. Always set the energized section **PWR** switch to **OFF** before energizing another section.

14. RF Frequency Accuracy

a. Performance Check

- (1) Connect frequency counter to TI **J3**. Short A6J9 (fig. 3) to ground.

NOTE

Adapt as necessary for frequency counter connection to TI **J3**. Use appropriate input channel on frequency counter to obtain desired frequency range reading.

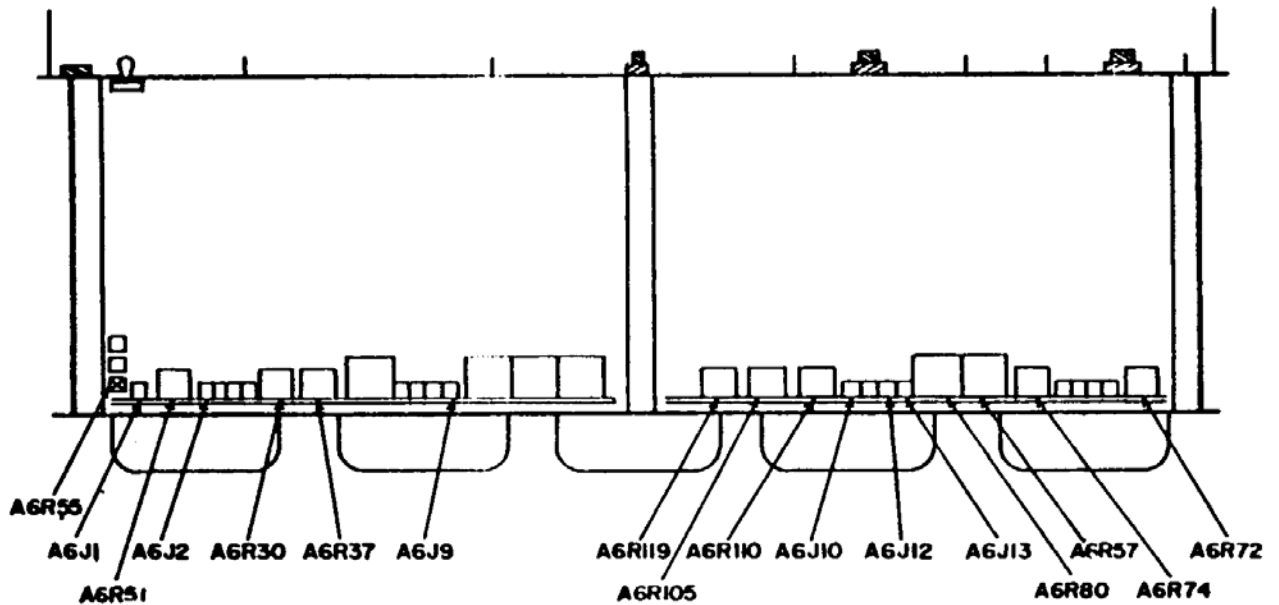

Figure 3. Test instrument - top view

- (2) Set **VOR PWR** switch to **ON** and **VOR 108.00-108.05** switch to **108.00**. If frequency counter does not indicate between 107.9973 and 108.0027 MHz, perform **b(1)** below.
- (3) Set **VOR 108.00-108.05** switch to **108.05**. If frequency counter does not indicate between 108.0473 and 108.0527 MHz, perform **b(2)** below.
- (4) Set **VOR PWR** switch to **OFF** and **LOC PWR** switch to **ON**.
- (5) Set **LOC 108.10-108.15** switch to **108.10**. If frequency counter does not indicate between 108.0973 and 108.1027 MHz, perform **b(3)** below.
- (6) Set **LOC 108.10-108.15** switch to **108.15**. If frequency counter does not indicate between 108.1473 and 108.1527 MHz, perform **b(4)** below.
- (7) Remove short from A6J9 (fig. 3) and connect to A6J1 (fig. 3). Set **LOC PWR** switch to **OFF** and **GLIDE SLOPE PWR** switch to **ON**.
- (8) Set **GLIDE SLOPE 334.70-334.55 (334.70-334.10)** switch to **334.70**. If frequency counter does not indicate between 334.69164 and 334.70836 MHz, perform **b(5)** below.

- (9) Set **GLIDE SLOPE 334.70-334.55 (334.70-334.10)** switch to **334.55 (334.10)**. If frequency counter does not indicate between 334.54164 and 334.55836 (334.0916 and 334.1084) MHz, perform **b(6)** below.
- (10) Set **GLIDE SLOPE PWR** switch to **OFF** and remove short from A6J1.
- (11) Remove connection from **J3** and connect to **J1**.
- (12) Set **MKR BCN PWR** switch to **ON**. If frequency counter does not indicate between 74.99625 and 75.00375 MHz, perform **b(7)** below.

b. Adjustments

- (1) Adjust A5L2 (fig. 4) for frequency counter indication of 108.0000 MHz (R).

NOTE

Boards A1 through A5 are identical

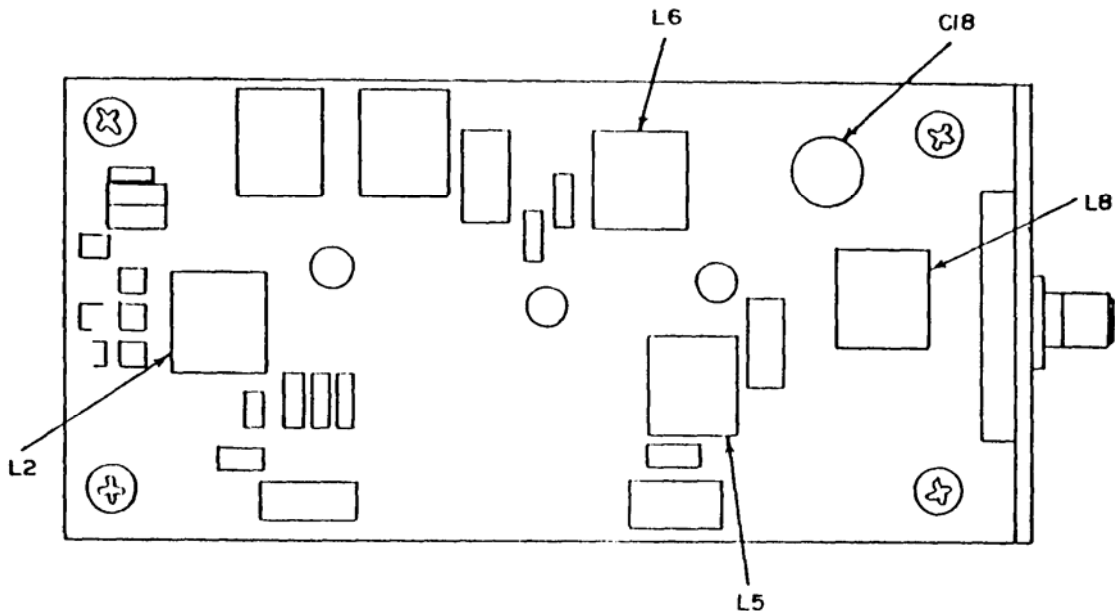

Figure 4. Adjustment locations – A1 through A5 boards.

- (2) Adjust A5L2 (fig. 4) for frequency counter indication of 108.0500 MHz. Repeat **a(2)** and (3) above for best compromise (R).
- (3) Adjust A4L2 (fig. 4) for frequency counter indication of 108.1000 MHz (R).
- (4) Adjust A4L2 (fig. 4) for frequency counter indication of 108.1500 MHz. Repeat **a(5)** and (6) above for best compromise (R).
- (5) Adjust A3L2 (fig. 4) for frequency counter indication of 334.70000 MHz (R).

(6) Adjust A3L2 (fig. 4) for frequency counter indication of 334.55000 (334.1000) MHz. Repeat a(8) and (9) above for best compromise (R).

(7) Adjust A1L2 (fig. 4) for frequency counter indication of 75.00000 MHz (R).

15. RF Level Output

a. Performance Check

(1) Connect power meter to TI **J1**. If power meter does not indicate greater than -20 dBm, perform b(1) below.

(2) Set **MKR BCN PWR** switch to **OFF** and **VOR PWR** switch to **ON**.

(3) Short A6J9 (fig. 3) to ground.

(4) Move power meter connection from **J1** to **J3**. If power meter does not indicate greater than -10 dBm, perform b(2) below.

(5) Set **VOR PWR** switch to **OFF** and **LOC PWR** switch to **ON**.

(6) Remove short from A6J9 and connect to A6J2 (fig. 3). If power meter does not indicate greater than -10 dbm, perform b(3) below.

(7) Set **LOC PWR** switch to **OFF** and **GLIDE SLOPE PWR** switch to **ON**.

(8) Remove short from A6J2 and connect to A6J1 (fig. 3). If power meter does not indicate greater than -20 dbm, perform b(4) below.

(9) Remove short from A6J1.

b. Adjustments

(1) Adjust A1C18 (fig. 4) for indication greater than -20 dBm. If indication is less than -20 dBm, adjust A1C18 for maximum indication and then adjust A1L8 (fig. 4) for indication greater than -20 dBm (R).

(2) Adjust A5C18 (fig. 4) for indication greater than -10 dBm. If indication is less than -10 dBm, adjust A5C18 for maximum indication and then adjust A5L8 (fig. 4) for indication greater than -10 dBm (R).

(3) Adjust A4C18 (fig. 4) for indication greater than -10 dBm. If indication is less than -10 dBm, adjust A4C18 for maximum indication and then adjust A4L8 (fig. 4) for indication greater than -10 dBm (R).

(4) Adjust A3C18 (fig. 4) for indication greater than -20 dBm. If indication is less than -20 dBm, adjust A3C18 for maximum indication and then adjust A3L8 (fig. 4) for indication greater than -20 dBm (R).

16. VOR Modulation

a. Performance Check

(1) Set **GLIDE SLOPE PWR** switch to **OFF** and **VOR PWR** switch to **ON**. If **VAR** light is illuminated, press light to extinguish.

- (2) Connect measuring receiver power sensor module to TI **J3**. Position measuring receiver controls to measure **AM**.
- (3) Press and hold **VOR 30VAR** and **30REF** pushbuttons. If measuring receiver does not indicate between 27 and 33 percent, perform **b(1)** below. Release **VOR 30VAR** and **30REF** pushbuttons.
- (4) Short A6J12 (fig. 3) to ground, using lead and adapters. If measuring receiver does not indicate an amplitude modulation between 27 and 33 percent, repeat **b(1)** below for best intolerance compromise between **a(3)** and (4).
- (5) Set **VOR 1020HZ** switch to **ON**. Press and hold **VOR 30VAR** pushbutton. Measuring receiver will indicate an amplitude modulation between 5 and 15 percent. Release **VOR 30VAR** pushbutton.
- (6) Connect audio analyzer to measuring receiver modulation output.
- (7) Press and hold **VOR 30VAR** pushbutton. Measure distortion. Audio analyzer will indicate less than 10 percent. Release **VOR 30VAR** pushbutton.
- (8) Set **VOR 1020HZ** switch to **OFF**.
- (9) Measure distortion. Audio analyzer will indicate less than 5 percent.
- (10) Remove short from A6J12 (fig. 3).
- (11) Press and hold **VOR 30VAR** and **30REF** pushbuttons. Measure distortion. If audio analyzer does not indicate less than 3 percent, perform **b(2)** through (4) below.
- (12) Disconnect audio analyzer from equipment setup and connect frequency counter to modulation output.
- (13) Press and hold **VOR 30VAR** and **30REF** pushbuttons. Frequency counter will indicate between 9959.004 and 9960.996 Hz. Release **VOR 30VAR** and **30REF** pushbuttons.
- (14) Short A6J12 (fig. 3) to ground. Frequency counter will indicate between 29.997 and 30.003 Hz.
- (15) Set **VOR 1020HZ** switch to **ON**.
- (16) Press and hold **VOR 30VAR** pushbutton. Frequency counter will indicate between 994.5 and 1045.5 Hz. Release **VOR 30VAR** pushbutton and set **VOR 1020HZ** switch to **OFF**.
- (17) Remove short from A6J12 (fig. 3)

b. Adjustments

- (1) Adjust A6R105 (fig. 3) for indication of 30 percent on measuring receiver (R).
- (2) Connect oscilloscope to A6J13 (fig. 3). Disconnect audio analyzer from modulation output and reconnect to A6J12 and chassis ground.

(3) Press **VOR 30VAR** and **30REF** pushbuttons and measure distortion. Adjust A6R80 (fig. 3) for minimum distortion while adjusting A6R57 (fig. 3) for a symmetrical square wave on oscilloscope (R).

(4) Disconnect equipment setup and reconnect audio analyzer to measuring receiver modulation output. Measure distortion. If distortion is still high, adjust A5L5 and A5L6 (fig. 4) for minimum distortion (R).

NOTE

If A5L5 and A5L6 (fig. 4) were adjusted, recheck paragraph **15a(4)** above VOR RF level.

17. VOR 9960 FM Deviation

a. Performance Check

(1) Connect oscilloscope **CH1** to TI A6J12 (fig. 3).

(2) Adjust oscilloscope controls for an 8 division sinewave display presentation at vertical setting of 200 mV/div, uncal, and horizontal setting of 100 μ s/div.

(3) Center sinewave on oscilloscope crt and adjust trigger level control to start sinewave at horizontal graticule centerline.

(4) Utilizing a delay time of 10 μ s/div, expand the fifth cycle portion of the TI signal as indicated in figure 5. Measure and verify the width of the jitter. Verify the deviation of the expanded jitter display, as shown in figure 6, is equal to 48.5 μ s \pm 3 μ s.

NOTE

The width of the jitter is proportional to the 9960 Hz FM signal. A 9960 Hz signal deviating \pm 480 Hz varies between 9480 and 10,440 Hz. The period of 10,440 Hz is 95.785 μ s and the time for five cycles is 478.925 μ s. The period of 9480 Hz is 105.485 μ s and the time for five cycles is 527.425 μ s. The difference between them (527.425 μ s minus 478.925 μ s) is 48.5 μ s. For a tolerance of 480 \pm 30 Hz deviation, the width of the jitter must be 48.5 \pm 3 μ s.

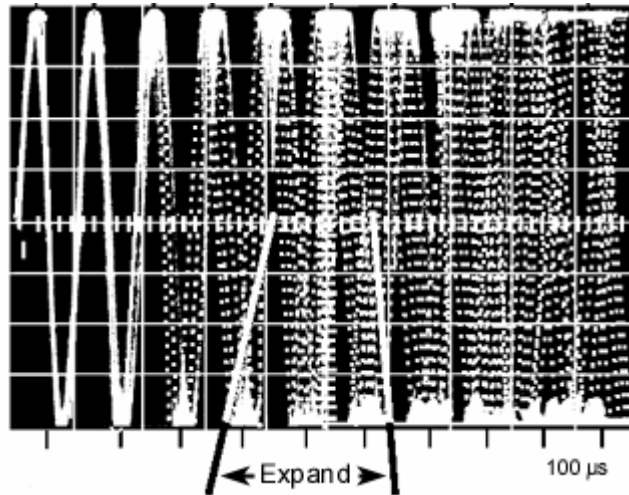

Figure 5. 9960 Hz FM Deviation Display.

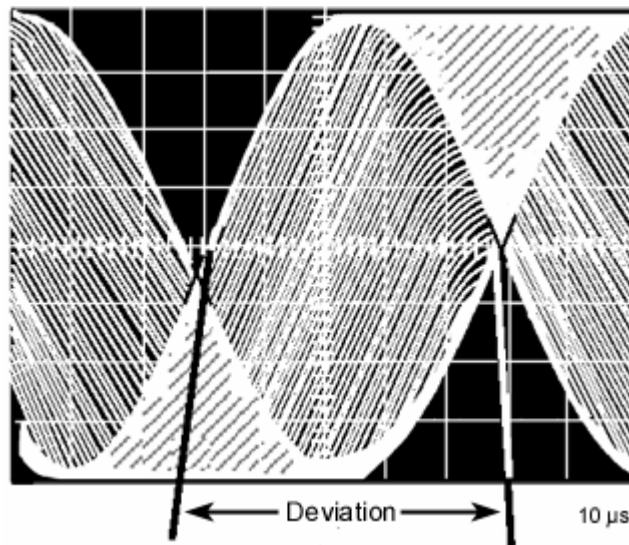

Figure 6. 9960 Hz FM Deviation Display with Jitter expanded.

b. Adjustments. No adjustments can be made.

18. VOR Zero

a. Performance Check

- (1) Connect zifor **COMP INPUT** to TI A6J9 (fig. 3). If zifor does not indicate between 359.3 and 000.7 degrees, perform **b** below.
- (2) Set **VOR** bearing switch to positions listed in table 5. Zifor will indicate within limits specified.

Table 5. VOR Bearing

Test instrument VOR bearing switch positions	Zifor indications	
	Min	Max
045	044.0	046.0
090	089.0	091.0
135	134.0	136.0
180	179.0	181.0
225	224.0	226.0
270	269.0	271.0
315	314.0	316.0

b. Adjustments. Adjust A6R72 (fig. 3) for indication of 000.0 degrees on zifor (R).

19. LOC DDM

a. Performance Check

(1) Set **VOR PWR** switch to **OFF** and **LOC PWR** switch to **ON**. If **VAR** light is illuminated, press light to extinguish.

(2) Connect digital multimeter to A6J2 (fig. 3).

(3) Press and hold **LOC 150 Hz** pushbutton. Record digital multimeter indication.

(4) Set **LEFT-OC-RIGHT** switch to **LEFT**. Record digital multimeter indication.

(5) Set **LEFT-OC-RIGHT** switch to **RIGHT**. Record digital multimeter indication.

(6) Release **LOC 150 Hz** pushbutton and press and hold **LOC 90 Hz** pushbutton. Record digital multimeter indication.

(7) Set **LEFT-OC-RIGHT** switch to **OC**. Record digital multimeter indication.

(8) Set **LEFT-OC-RIGHT** switch to **LEFT**. Record digital multimeter indication.

(9) Release **LOC 90 Hz** pushbutton.

(10) Subtract value recorded in (7) above from value recorded in (3) above. If difference is not less than 1 mV, perform **b** below.

(11) Divide value recorded in (8) above by value recorded in (4) above. Ratio will be between 2.02 and 2.55.

(12) Divide value recorded in (5) above by value recorded in (6) above. Ratio will be between 2.02 and 2.55.

b. Adjustments. Adjust A6R30 (fig. 3) and repeat a(3) through (10) above until value computed in a(10) above is less than 1 mV (R).

20. LOC Modulation

a. Performance Check

(1) Connect measuring receiver power sensor module to TI **J3**. Position measuring receiver controls to measure **AM**. Set **LEFT-OC-RIGHT** switch to **OC**.

- (2) Press and hold **LOC 90 Hz** pushbutton. If measuring receiver does not indicate an amplitude modulation between 18 and 22 percent, perform **b** below. Release **LOC 90 Hz** pushbutton.
- (3) Press and hold **LOC 150 Hz** pushbutton. If measuring receiver does not indicate an amplitude modulation between 18 and 22 percent, perform **b** below. Release **LOC 150 Hz** pushbutton.
- (4) Set **LOC 1020 Hz** switch to **ON** and press and hold both **90 Hz** and **150 Hz** pushbuttons. Measuring receiver will indicate an amplitude modulation between 5 and 15 percent. Release **90 Hz** and **150 Hz** pushbuttons.
- (5) Connect audio analyzer to measuring receiver modulation output.
- (6) Press and hold both **LOC 90 Hz** and **150 Hz** pushbuttons. Measure distortion. Audio analyzer will indicate less than 10 percent. Release **LOC 90 Hz** and **150 Hz** pushbuttons.
- (7) Set **LOC 1020 Hz** switch to **OFF**.
- (8) Press and hold **LOC 90 Hz** pushbutton. Measure distortion. Audio analyzer will indicate less than 5 percent. Release **LOC 90 Hz** pushbutton.
- (9) Press and hold **LOC 150 Hz** pushbutton. Measure distortion. Audio analyzer will indicate less than 5 percent. Release **LOC 150 Hz** pushbutton.
- (10) Disconnect audio analyzer from equipment setup and connect frequency counter to **MODULATION OUTPUT**.
- (11) Press and hold **LOC 150 Hz** pushbutton. Frequency counter will indicate between 89.91 and 90.09 Hz. Release **LOC 150 Hz** pushbutton.
- (12) Press and hold **LOC 90 Hz** pushbutton. Frequency counter will indicate between 149.85 and 150.15 Hz. Release **LOC 90 Hz** pushbutton.
- (13) Set **LOC 1020 Hz** switch to **ON**.
- (14) Press and hold both **LOC 90 Hz** and **150 Hz** pushbuttons. Frequency counter will indicate between 994.5 and 1045.5 Hz. Release both **LOC 90 Hz** and **150 Hz** pushbuttons.
- (15) Set **LOC 1020 Hz** switch to **OFF**.

b. Adjustments. Adjust A6R51 (fig. 3) for measuring receiver indication of 20 percent. Repeat **a**(2) and (3) above for best compromise of adjustment (R).

21. Glide Slope DDM

a. Performance Check

- (1) Set **LOC PWR** switch to **OFF** and **GLIDE SLOPE PWR** switch to **ON**. If **VAR** light is illuminated, press light to extinguish.

- (2) Connect digital multimeter to A6J1 (fig. 3).
 - (3) Press and hold **GLIDE SLOPE 150 Hz** pushbutton. Record digital multimeter indication.
 - (4) Set **UP-OC-DOWN** switch to **UP**. Record digital multimeter indication.
 - (5) Set **UP-OC-DOWN** switch to **DOWN**. Record digital multimeter indication.
 - (6) Release **GLIDE SLOPE 150 Hz** pushbutton and press and hold **GLIDE SLOPE 90 Hz** pushbutton. Record digital multimeter indication.
 - (7) Set **UP-OC-DOWN** switch to **OC**. Record digital multimeter indication.
 - (8) Set **UP-OC-DOWN** switch to **UP**. Record digital multimeter indication.
 - (9) Release **GLIDE SLOPE 90 Hz** pushbutton.
 - (10) Subtract value recorded in (7) above from value recorded in (3) above. If difference is not less than 2 mV, perform **b** below.
 - (11) Divide value recorded in (8) above by value recorded in (4) above. Ratio will be between 1.46 and 1.66.
 - (12) Divide value recorded in (5) above by value recorded in (6) above. Ratio will be between 1.46 and 1.66.
- b. Adjustments.** Adjust A6R37 (fig. 3) until value computed in **a**(10) above is less than 2 mV (R).

22. Glide Slope Modulation

a. Performance Check

- (1) Connect measuring receiver power sensor module to TI **J3**. Position measuring receiver controls to measure **AM**. Set **UP-OC-DOWN** to **OC**.
 - (2) Press and hold **GLIDE SLOPE 90 Hz** pushbutton. If measuring receiver does not indicate an amplitude modulation between 36 and 44 percent, perform **b** below. Release **LOC 90 Hz** pushbutton.
 - (3) Press and hold **GLIDE SLOPE 150 Hz** pushbutton. If measuring receiver does not indicate an amplitude modulation between 36 and 44 percent, perform **b** below. Release **LOC 150 Hz** pushbutton.
 - (4) Connect audio analyzer to measuring receiver modulation output.
 - (5) Press and hold **GLIDE SLOPE 90 Hz** pushbutton. Measure distortion. Audio analyzer will indicate less than 5 percent. Release **GLIDE SLOPE 90 Hz** pushbutton.
 - (6) Press and hold **GLIDE SLOPE 150 Hz** pushbutton. Measure distortion. Audio analyzer will indicate less than 5 percent. Release **GLIDE SLOPE 150 Hz** pushbutton.
- b. Adjustments.** Adjust A6R55 (fig. 3) for measuring receiver indication of 40 percent. Repeat **a**(2) and (3) above for best compromise of adjustment (R).

23. MKR BCN

a. Performance Check

- (1) Set **GLIDE SLOPE PWR** switch to **OFF** and **MKR BCN PWR** switch to **ON**.
- (2) Connect measuring receiver power sensor module to TI **J1**. Position measuring receiver controls to measure **AM**.
- (3) Connect frequency counter to measuring receiver modulation output.
- (4) Press and hold **MKR BCN** yellow (1300 Hz) pushbutton. If frequency counter does not indicate between 1274 And 1326 Hz, perform **b(1)** below. Release **MKR BCN** yellow pushbutton.
- (5) Press and hold **MKR BCN** blue (400 Hz) pushbutton. If frequency counter does not indicate between 392 and 408 Hz, perform **b(2)** below. Release **MKR BCN** blue pushbutton.
- (6) Press and hold **MKR BCN** white (3000 Hz) pushbutton. If frequency counter does not indicate between 2940 and 3060 Hz, perform **b(2)** below. Release **MKR BCN** white pushbutton.
- (7) Press and hold **MKR BCN** yellow pushbutton. If measuring receiver does not indicate an amplitude modulation between 90 and 100 percent, perform **b(3)** below. Release **MKR BCN** yellow pushbutton.
- (8) Repeat (7) above for **MKR BCN** blue pushbutton.
- (9) Repeat (7) above for **MKR BCN** white pushbutton.
- (10) Disconnect frequency counter from equipment setup and connect audio analyzer to modulation output.
- (11) Press and hold **MKR BCN** yellow pushbutton. Measure distortion. Audio analyzer will indicate less than 15 percent. Release **MKR BCN** yellow pushbutton.
- (12) Repeat (11) above for **MKR BCN** blue pushbutton (400 Hz).
- (13) Repeat (11) above for **MKR BCN** white pushbutton (3000 Hz).

b. Adjustments

- (1) Adjust A6R110 (fig. 3) until frequency counter indicates 1300 Hz (R).
- (2) Repeat **a(4)** and **b(1)** above and adjust A6R110 for best in-tolerance condition.
- (3) Adjust A6R119 (fig. 3) until measuring receiver indicates an amplitude modulation of 95 percent (R). If required, adjust A6R119 for best in-tolerance condition for the three modulated frequencies.

24. Final Procedure

- a. Deenergize and disconnect all equipment and reinstall TI in its case.
- b. Annotate and affix DA label/form in accordance with TB 750-25.

THESE ARE THE INSTRUCTIONS FOR SENDING AN ELECTRONIC 2028

The following format must be used if submitting an electronic 2028. The subject line must be exactly the same and all fields must be included; however, only the following fields are mandatory: 1, 3, 4, 5, 6, 7, 8, 9, 10, 13, 15, 16, 17, and 27.

From: "Whomever" whomever@avma27.army.mil

To: 2028@redstone.army.mil

Subject: DA Form 2028

1. **From:** Joe Smith
2. **Unit:** Home
3. **Address:** 4300 Park
4. **City:** Hometown
5. **St:** MO
6. **Zip:** 77777
7. **Date Sent:** 19-Oct-93
8. **Pub No:** TB 9-6625-xxxx-35
9. **Pub Title:** Calibration Procedure for ...
10. **Publication Date:**
11. **Change Number:**
12. **Submitted Rank:** MSG
13. **Submitter Fname:** Joe
14. **Submitter Mname:** T
15. **Submitter Lname:** Smith
16. **Submitter Phone:** (123) 123-1234
17. **Problem:** 1
18. **Page:** 2
19. **Paragraph:** 3
20. **Line:** 4
21. **NSN:** 5
22. **Reference:** 6
23. **Figure :** 7
24. **Table:** 8
25. **Item:** 9
26. **Total:** 123
27. **Text:**

This is the text for the problem below line 27.

By Order of the Secretary of the Army:

ERIC K. SHINSEKI
General, United States Army
Chief of Staff

OFFICIAL:

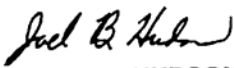
JOEL B. HUDSON
Administrative Assistant to the
Secretary of the Army

0236404

Distribution:

To be distributed in accordance with initial distribution number (IDN) 342260, requirements for calibration procedure TB 9-6625-2171-35.

